

公司简介

Company Introduction

HOLMAN AUTO PARTS

HOLMAN Auto Parts is located in Cangzhou City, Hebei Province, China. Which is a genuine and professional manufacture and export various of wheel weights, tire valve, tire seals and tire repair tools etc. Our company was founded in 1994 and has been developed very fast, the enterprise management, employee quality, technical equipment, production technology and supporting facilities, etc all have achieved international standard, so that the company take the leading position in the same field all of the world. All of our products are superior in quality and moderate in price, Which mainly export to Germany, France, Poland, Canada, Australia, Italy, North America and so on.

As increasing your profit and bring you a prosperous business, we can submit you best services.

- EXCELLENT QUALITY
- COMPETITIVE PRICE
- PUNCTUAL DELIVERY
- PROFESSIONAL QUALITY CONTROL
- HONEST SERVICE

与世界同步是我们的目标，
诚实守信是我们的准则！

HOLMAN® 河北特莱斯汽车配件有限公司
HEBEI HOLMAN Auto Parts Co.,Ltd.





Fe Adhesive wheel weights, car

H-8101 Zinc Plated



铁质粘贴

- Fe Adhesive wheel weight
- 5g x 12 segments
- Zinc Plated / Epoxy coated / Black coated With Blue Tape
- L x W x H: 140 x 19 x 3.8mm
- Box Qty: 100 strips/box



H-8103 Epoxy coated

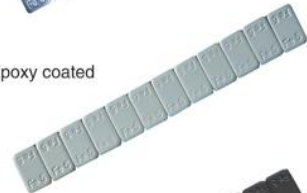

H-8105 Black coated



H-8101E Zinc Plated

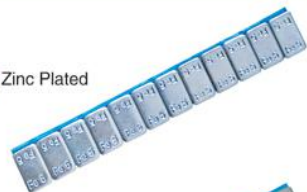

铁质粘贴

- Fe Adhesive wheel weight
- 5g x 12 segments
- Zinc Plated / Epoxy coated / Black coated
- Blue Easy-Peel Tape
- L x W x H: 140 x 19 x 3.8mm
- Box Qty: 100 strips/box



H-8103E Epoxy coated

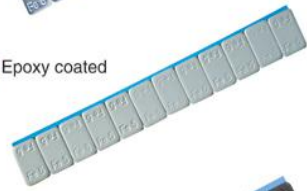

H-8105E Black coated

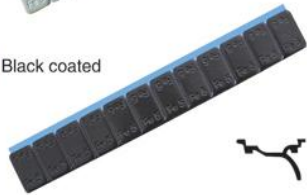

Fe Adhesive wheel weights, car

H-8102 Zinc Plated

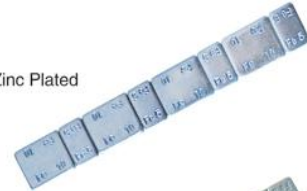

铁质粘贴

- Fe Adhesive wheel weight
- (5g+10g) x 4 segments
- Zinc Plated / Epoxy coated / Black coated With Blue Tape
- L x W x H: 140 x 19 x 3.8mm
- Box Qty: 100 strips/box



H-8104 Epoxy coated

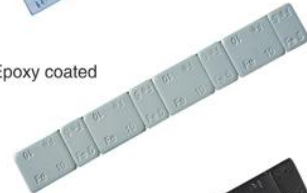

H-8106 Black coated

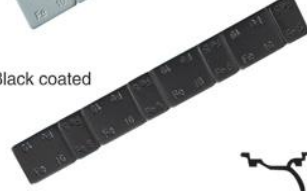

H-8102E Zinc Plated



铁质粘贴

- Fe Adhesive wheel weight
- (5g+10g) x 4 segments
- Zinc Plated / Epoxy coated / Black coated
- Blue Easy-Peel Tape
- L x W x H: 140 x 19 x 3.8mm
- Box Qty: 100 strips/box



H-8104E Epoxy coated

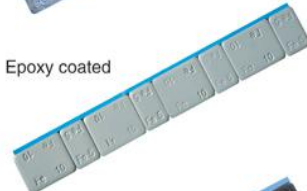

H-8106E Black coated

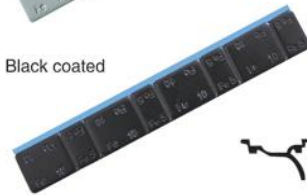



Fe Adhesive wheel weights, car

H-8107 Zinc Plated

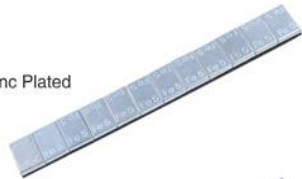

NEW



铁质粘贴 (直角)

- Fe Adhesive wheel weight New type
- 5g x 12 segments
- Zinc Plated / Epoxy coated / Black coated With Blue Tape
- L x W x H: 140 x 19 x 3.8mm
- Box Qty: 100 strips/box



H-8109 Epoxy coated



H-8111 Black coated



H-8107E Zinc Plated



NEW



铁质粘贴 (直角)

- Fe Adhesive wheel weight New type
- 5g x 12 segments
- Zinc Plated / Epoxy coated / Black coated
- Blue Easy-Peel Tape
- L x W x H: 140 x 19 x 3.8mm
- Box Qty: 100 strips/box



H-8109E Epoxy coated

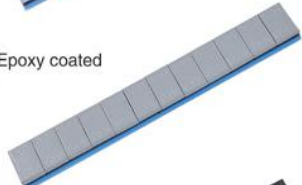

H-8111E Black coated

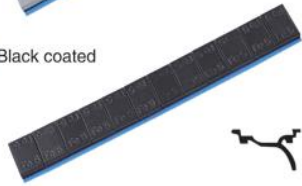

Fe Adhesive wheel weights, car

H-8108 Zinc Plated



NEW



铁质粘贴 (直角)

- Fe Adhesive wheel weight New type
- (5g+10g) x 4 segments
- Zinc Plated / Epoxy coated / Black coated With Blue Tape
- L x W x H: 140 x 19 x 3.8mm
- Box Qty: 100 strips/box



H-8110 Epoxy coated

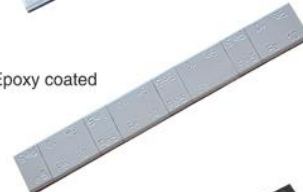

H-8112 Black coated

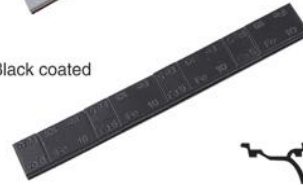

H-8108E Zinc Plated

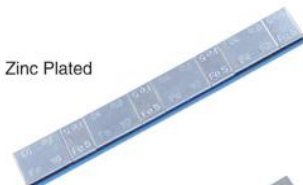

NEW



铁质粘贴 (直角)

- Fe Adhesive wheel weight New type
- (5g+10g) x 4 segments
- Zinc Plated / Epoxy coated / Black coated
- Blue Easy-Peel Tape
- L x W x H: 140 x 19 x 3.8mm
- Box Qty: 100 strips/box



H-8110E Epoxy coated

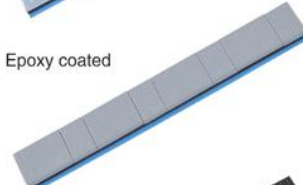

H-8112E Black coated

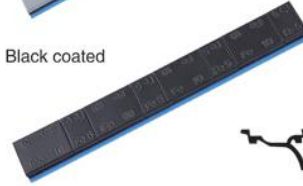



Fe Adhesive wheel weights, car

H-8113 Zinc Plated



H-8114 Epoxy coated

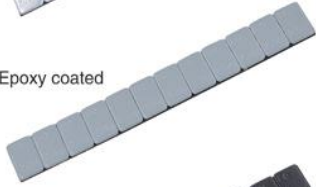

H-8115 Black coated



铁质粘贴

- Fe Adhesive wheel weight For Motorcycle
- 2.5g x 12 segments
- Zinc Plated / Epoxy coated / Black coated With Blue Tape
- L x W x H: 140 x 19 x 2.3mm
- Box Qty: 100 strips/box



Fe Adhesive wheel weights, car

H-8113E Zinc Plated

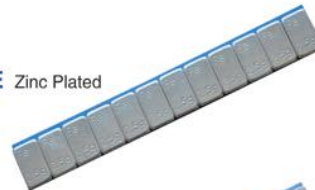

H-8114E Epoxy coated

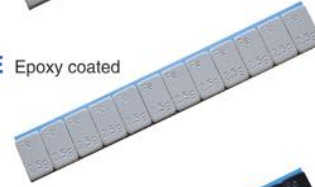

H-8115E Black coated



铁质粘贴

- Fe Adhesive wheel weight For Motorcycle
- 2.5g x 12 segments
- Zinc Plated / Epoxy coated / Black coated
- Blue Easy-Peel Tape
- L x W x H: 140 x 19 x 2.3mm
- Box Qty: 100 strips/box



5 KGS



H-2104

- Adhesive wheel weight in Roll
- 5g x 1000 segments / 1/4oz(7G) x 704 segments
- 5 KGS / Roll
- Available in Zinc Plated , Black and Gray Coated



Easy-Peel Extended Tape

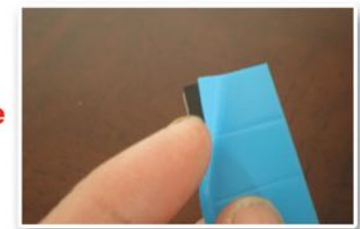

5 KGS



H-2105

- Adhesive wheel weights in Refill Roll
- 5g x 1000 segments / 1/4oz(7G) x 704 segments
- 5 KGS / Roll
- Available in Zinc Plated , Black and Gray Coated

6 KGS



H-2107

- Adhesive wheel weight in Roll
- 5g x 1200 segments / 1/4oz(7G) x 840 segments
- 6 KGS / Roll
- Available in Zinc Plated , Black and Gray Coated



Fe Clip-on wheel weights, car



H-1103 铁质钢轮

- Fe clip-on wheel weight for Steel rims
- Surface: Zinc plated and epoxy coating
- Sizes in Gram
 - 5g-30g 100 pcs/box
 - 35g-60g 50 pcs/box



H-1104 铁质铝轮

- Fe clip-on wheel weight for Alloy rims
- Surface: Zinc plated and epoxy coating
- Sizes in Gram
 - 5g-30g 100 pcs/box
 - 35g-60g 50 pcs/box



H-1105 铁质钢轮

- Fe clip-on wheel weight for Steel rims
- Surface: Zinc plated and epoxy coating
- Sizes in Gram
 - 5g-30g 100 pcs/box
 - 35g-60g 50 pcs/box



H-1106 铁质铝轮

- Fe clip-on wheel weight for Alloy rims
- Surface: Zinc plated and epoxy coating
- Sizes in Gram
 - 5g-30g 100 pcs/box
 - 35g-60g 50 pcs/box



Zn Clip-on wheel weights, car



H-3101 Die-Casting 锌质钢轮压铸

- Zinc clip-on wheel weights for Steel rims Die-casting
- Surface: Epoxy coating
- Sizes in Gram
 - 5g-30g 100 pcs/box
 - 35g-60g 50 pcs/box



H-3105 Die-Casting 锌质铝轮压铸

- Zinc clip-on wheel weights for Alloy rims Die-casting
- Surface: Epoxy coating
- Sizes in Gram
 - 5g-30g 100 pcs/box
 - 35g-60g 50 pcs/box

Package Show 包装展示



1. Clip-on Wheel Weights

- 5g-30g 100 pcs/box
- 35g-60g 50 pcs/box



2. Adhesive Wheel Weights

- 60g / strip
- 100 strips/box
- 4 boxes/carton
- 60 cartons/pallet
- 60g / strip
- 50 strips/box
- 8 boxes/carton
- 60 cartons/pallet



Zn Clip-on wheel weights, car



H-3101 锌质钢轮

- Zn clip-on wheel weight for Steel rims
- Surface: Epoxy coating
- Sizes in Gram
- 5g-30g 100 pcs/box
- 35g-60g 50 pcs/box



H-3104 锌质钢轮

- Zn clip-on wheel weight for Steel rims
- Surface: Epoxy coating
- Sizes in Gram
- 5g-30g 100 pcs/box
- 35g-60g 50 pcs/box



H-3105 锌质铝轮

- Zn clip-on wheel weight for Alloy rims
- Surface: Epoxy coating
- Sizes in Gram
- 5g-30g 100 pcs/box
- 35g-60g 50 pcs/box



H-3107 锌质铝轮

- Zn clip-on wheel weight for Alloy rims
- Surface: Epoxy coating
- Sizes in Gram
- 5g-30g 100 pcs/box
- 35g-60g 50 pcs/box



Zn Adhesive wheel weights, car



H-4101 锌质粘贴

- Zn Adhesive wheel weight
- (5g+10g) × 4 segments
- Surface: Epoxy coating
- L × W × H: 155 × 18 × 3.8mm
- Box Qty: 50 or 100 strips/box



H-4102 锌质粘贴

- Zn Adhesive wheel weight
- 5g × 12 segments
- Surface: Epoxy coating
- L × W × H: 155 × 18 × 3.8mm
- Box Qty: 50 or 100 strips/box

NEW



H-4104 锌质粘贴

- Zn Adhesive wheel weight Curved
- 5g-40g
- Surface: Epoxy coating
- Box Qty: 100 strips/box

PRODUCT DETAIL

• Epoxy Coating



• The Back

• Zn Adhesive





Pb Clip-on wheel weights



H-5101 铅质钢轮

- Pb clip-on wheel weight for Steel rims
- Surface: Uncoated or Coated
- Sizes in Gram
 - 5g-30g 100 pcs/box
 - 35g-60g 50 pcs/box



H-5102 铅质铝轮

- Pb clip-on wheel weight for Alloy rims
- Surface: Uncoated or Coated
- Sizes in Gram
 - 5g-30g 100 pcs/box
 - 35g-60g 50 pcs/box



H-5103 铅质铝轮

- Pb clip-on wheel weight for Alloy rims
- Surface: Uncoated or Coated
- Sizes in Gram
 - 5g-30g 100 pcs/box
 - 35g-60g 50 pcs/box



H-5104 铅质卡车

- Pb clip-on wheel weight for Truck
- Surface: Uncoated or Coated
- Sizes in Gram
 - 50g-500g



Pb Clip-on wheel weights, Truck



H-5105 铅质卡车

- Pb clip-on wheel weight for Truck
- Surface: Uncoated or Coated
- Sizes in Gram
 - 50g-500g



H-5106 铅质卡车

- Pb clip-on wheel weight for Truck
- Surface: Uncoated or Coated
- Sizes in Gram
 - 50g-500g



H-5107 铅质卡车

- Pb clip-on wheel weight for Truck
- Surface: Uncoated or Coated
- Sizes in Gram
 - 50g-500g



H-5108 铅质卡车

- Pb clip-on wheel weight for Truck
- Surface: Uncoated or Coated
- Sizes in Gram
 - 50g-500g



Pb Adhesive wheel weights, car



H-6101 铅质粘贴

- Pb Adhesive wheel weight
- (5g+10g) × 4 segments
- Surface: Uncoated or Coated
- L × W × H: 102 × 18 × 4.0mm
- Box Qty: 50 or 100 strips/box



Pb Adhesive wheel weights, car



H-6110 铅质粘贴

- Pb Adhesive wheel weight
- (5g+10g) × 4 segments
- Surface: Uncoated or Coated
- L × W × H: 101 × 11 × 5.0mm
- Box Qty: 50 or 100 strips/box



H-6102 铅质粘贴

- Pb Adhesive wheel weight
- 5g × 12 segments
- Surface: Uncoated or Coated
- L × W × H: 102 × 18 × 4.0mm
- Box Qty: 50 or 100 strips/box



H-6111 铅质粘贴

- Pb Adhesive wheel weight For Motorcycle
- 2.5g × 6 + 5g × 7 segments
- Surface: Uncoated or Coated
- L × W × H: 150 × 15 × 4.0mm
- Box Qty: 50 or 100 strips/box

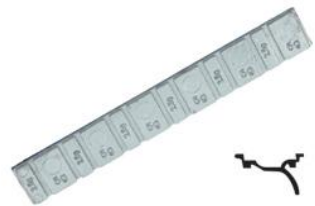

H-6103 铅质粘贴

- Pb Adhesive wheel weight
- (2.5g+5g) × 6 segments
- Surface: Uncoated or Coated
- L × W × H: 109 × 18 × 3.8mm
- Box Qty: 50 or 100 strips/box



H-6112 铅质粘贴

- Pb Adhesive wheel weight For Motorcycle
- 5g × 10 segments
- Surface: Uncoated or Coated
- L × W × H: 101 × 11 × 5.0mm
- Box Qty: 50 or 100 strips/box



H-6104 铅质粘贴

- Pb Adhesive wheel weight
- (7.5g+15g) × 4 segments
- Surface: Uncoated or Coated
- L × W × H: 109 × 18 × 8.5mm
- Box Qty: 50 or 100 strips/box



H-6105 铅质卡车

- Pb Adhesive wheel weight
- 20g × 5 segments
- Surface: Uncoated or Coated
- L × W × H: 108 × 15 × 7.0mm
- Box Qty: 20 strips/box



Pb Adhesive wheel weights



H-6113 铅质卡车

- Pb Adhesive wheel weight
- 50g x 4 segments
- Surface: Uncoated or Coated
- L x W x H: 105 x 25 x 7.5mm
- Box Qty: 20 strips/box



H-6106 铅质卡车

- Pb Adhesive wheel weight
- 25g x 4 segments
- Surface: Uncoated or Coated
- L x W x H: 110 x 19 x 5.5mm
- Box Qty: 40 strips/box



H-6107 铅质卡车

- Pb Adhesive wheel weight
- 25g x 4 segments
- Surface: Uncoated or Coated
- L x W x H: 105 x 19 x 5.5mm
- Box Qty: 40 strips/box



H-6108 铅质卡车

- Pb Adhesive wheel weight
- 50g x 4 segments
- Surface: Uncoated or Coated
- L x W x H: 105 x 25 x 7.5mm
- Box Qty: 20 strips/box



H-6109 铅质卡车

- Pb Adhesive wheel weight
- 20g x 10 segments
- Surface: Uncoated or Coated
- L x W x H: 180 x 17 x 5.8mm
- Box Qty: 20 strips/box



Wheel Balance Weights



Wheel Weights For American Marketing OZ Series



• STEEL WHEEL WEIGHTS

“Green Wheels, Green World” is our motto. Steel wheel weights is the best choice for alternatives to lead on the wheel balancing. Because of Steel having high density, smaller size, cost advantage and environmentally-friendly composition, steel significantly surpasses all other lead alternatives, including zinc.

Fe
VS.
Pb
VS.
Zn



Adhesive wheel weights Installation instructions

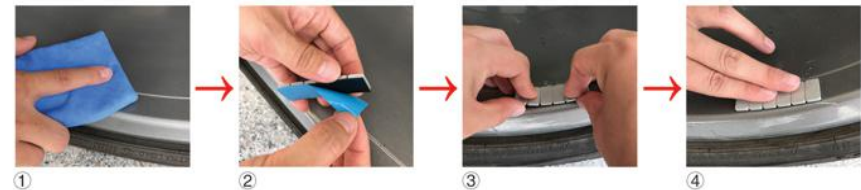



Fe Adhesive wheel weights OZ series

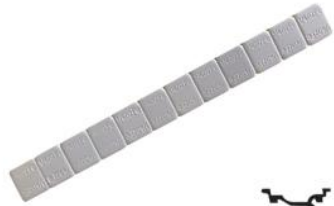

Low Profile



Fe-1025 铁质粘贴

- Fe Adhesive wheel weight
- 1/4oz x 12 segments
- Surface: Zinc plated and epoxy coating
- L x W x H: 194 x 19 x 3.8mm
- Box Qty: 30 or 48 or 52 strips/box



Fe Adhesive wheel weights OZ series



Low Profile



Fe-4025 铁质粘贴 (直角)

- Fe Adhesive wheel weight New type
- 1/4oz x 12 segments
- Surface: Zinc plated and epoxy coating
- L x W x H: 194 x 19 x 3.8mm
- Box Qty: 30 or 48 or 52 strips/box



Standard Profile



Fe-2025 铁质粘贴

- Fe Adhesive wheel weight
- 1/4oz x 12 segments
- Surface: Zinc plated and epoxy coating
- L x W x H: 153 x 19 x 4.6mm
- Box Qty: 48 or 52 strips/box



Fe-1100 铁质粘贴

- Fe Adhesive wheel weight
- 1oz x 6 segments
- Surface: Zinc plated and epoxy coating
- L x W x H: 208 x 19 x 6.8mm
- Box Qty: 15 strips/box



Standard Profile



Fe-2050 铁质粘贴

- Fe Adhesive wheel weight
- 1/2oz x 6 segments
- Surface: Zinc plated and epoxy coating
- L x W x H: 146 x 19 x 4.8mm
- Box Qty: 48 or 52 strips/box



Trapezoid Shape



Fe-5025 铁质粘贴

- Fe Adhesive wheel weight
- 1/4oz x 12 segments
- Surface: Zinc plated and epoxy coating
- L x W x H: 155 x 19 x 4.0mm
- Box Qty: 48 or 52 strips/box



Standard Profile



Fe-1050 铁质粘贴

- Fe Adhesive wheel weight for Trucks and SUVs
- 1/2oz x 6 segments
- Surface: Zinc plated and epoxy coating
- L x W x H: 123 x 19 x 5.5mm
- Box Qty: 48 or 52 strips/box



Trapezoid Shape



Fe-3050 铁质粘贴

- Fe Adhesive wheel weight
- 1/2oz x 12 segments
- Surface: Zinc plated and epoxy coating
- L x W x H: 178 x 19 x 3.8mm
- Box Qty: 48 or 52 strips/box



Pb Clip-on wheel weights OZ series



Pb-P Series

- Pb clip-on wheel weight for standard passenger car 13" - 15" steel wheels
- Surface: Uncoated or Coated
- Sizes in OZ
- 0.25 oz — 3.0 oz



Pb-AW Series

- Pb clip-on wheel weight for Alloy wheel
- Surface: Uncoated or Coated
- Sizes in OZ
- 0.25 oz — 3.0 oz

Chrysler	All 1980-1989
Dodge	All 1980-1989
GM	All 1980-1987
	Some used 1988-2000



Pb-MC Series

- Pb clip-on wheel weight for Alloy wheel
- Surface: Uncoated or Coated
- Sizes in OZ
- 0.25 oz — 3.0 oz

Chrysler	All 1990-2008
Dodge	All 1998-2010
Ford	All 1980-2010
GM	All 1995-2010



Pb-FN Series

- Pb clip-on wheel weight for Alloy wheel
- Surface: Uncoated or Coated
- Sizes in Gram
- 5g-60g

Honda	All 1989-2010
Toyota	All 1990-2010
Lexus	All 1990-2010
Nissan	All 1990-2010
Acura	All 1989-2010
Infiniti	All 1990-2010



Pb wheel weights OZ series



Pb-IAW Series

- Pb clip-on wheel weight for Alloy wheels
- Surface: Uncoated or Coated
- Sizes in Gram
- 5g-60g

Audi	All 1980-1996
BMW	All 1980-2005
Cadillac	All 1997-2001
Jaguar	All 1988-2010
Kia	All 1994-2010
Nissan	All 1979-1989
Toyota	All 1980-1989
Volkswagen	All 1980-1996
Volvo	All 1980-2010



Pb-TN Series

- Pb clip-on wheel weight
- Surface: Uncoated or Coated
- Sizes in OZ
- 0.25 oz — 3.0 oz

Cadillac	Escalade
Chevrolet	All Full Size w/Steel Wheels 1988-2009
	All Full Size w/Alloy Wheels 1999-2009
Dodge	All Full Size w/Steel Wheels 1993-2009
GMC	All Full Size w/Steel Wheels 1988-2009
	All Full Size w/Alloy Wheels 1999-2009
Lincoln	Navigator 1998-2009



Pb-1025 **铅质粘贴**

- Pb Adhesive wheel weight
- 1/4oz x 12 segments
- Surface: Uncoated or Coated
- L x W x H: 155 x 19 x 3.0mm
- Box Qty: 48 or 52 strips/box



Standard Profile

Clip-on wheel weights Installation instructions





Pb Adhesive wheel weights OZ series

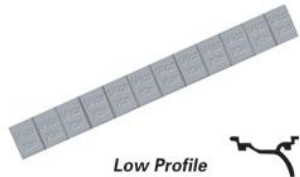

Low Profile



Pb-2025 铅质粘贴

- Pb Adhesive wheel weight
- 1/4oz x 12 segments
- Surface: Uncoated or Coated
- L x W x H: 155 x 19 x 2.2mm
- Box Qty: 52 strips/box

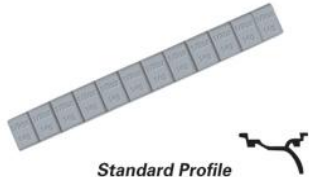

Standard Profile



Pb-2050 铅质粘贴

- Pb Adhesive wheel weight
- 1/2oz x 12 segments
- Surface: Uncoated or Coated
- L x W x H: 155 x 19 x 5mm
- Box Qty: 28 strips/box

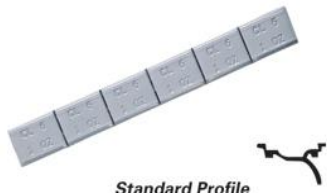

Standard Profile



Pb-2100 铅质粘贴

- Pb Adhesive wheel weight
- 1oz x 6 segments
- Surface: Uncoated or Coated
- L x W x H: 155 x 19 x 5mm
- Box Qty: 28 strips/box



- Adhesive wheel weight
- All Epoxy coated Available in Black and Gray



Zn wheel weights OZ series



Zn-P Series

- Zn clip-on wheel weight for standard passenger car 13" -15" steel wheels
- Surface: Uncoated or Coated
- Sizes in OZ
- 0.25 oz — 3.0 oz



Zn-AW Series

- Zn clip-on wheel weight for Alloy wheel
- Surface: Uncoated or Coated
- Sizes in OZ
- 0.25 oz — 3.0 oz

Chrysler	All 1980-1989
Dodge	All 1980-1989
GM	All 1980-1987
	Some used 1988-2000



Zn-MC Series

- Zn clip-on wheel weight for Alloy wheel
- Surface: Uncoated or Coated
- Sizes in OZ
- 0.25 oz — 3.0 oz

Chrysler	All 1990-2008
Dodge	All 1998-2010
Ford	All 1980-2010
GM	All 1995-2010



Zn-FN Series

- Zn clip-on wheel weight for Alloy wheel
- Surface: Uncoated or Coated
- Sizes in Gram
- 5g-60g

Honda	All 1989-2010
Toyota	All 1990-2010
Lexus	All 1990-2010
Nissan	All 1990-2010
Acura	All 1989-2010
Infiniti	All 1990-2010



Snap-in Tubeless Rubber Valves

轿车、轻卡车卡扣式真空胎气门嘴



General used for Passenger Cars, Trailers and Light Trucks For use to 65PSI/4.5Bar cold inflation pressure maximum Recommended maximum rim thickness at rim hole is .156"/4mm



TR No.	ETRTO	Rim Hole	A	B	C
TR412	V2.03.6	.453"/11.3mm	33	22	15
TR413	V2.03.1	.453"/11.3 mm	42.5	32	15
TR414	V2.03.2	.453"/11.3 mm	48.5	38	15
TR414L	V2.03.8	.453"/11.3 mm	56.5	46	15
TR418	V2.03.4	.453"/11.3 mm	61.5	51	15
TR423	-	.453"/11.3 mm	74	63.5	15
TR415	V2.03.3	.625"/15.7 mm	42.5	32	19.2
TR425	-	.625"/15.7 mm	61.5	51	19.2

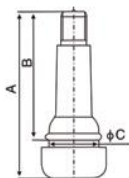

Chrome Sleeved Snap-in Tire Valves

镀铬真空胎气门嘴-直型



TR No.	Sleeve	Cap
TR412C	S412	ST
TR413C	S413	ST
TR415C	S415	ST
TR414C	S414	ST
TR418C	S418	ST

镀铬真空胎气门嘴-喇叭型



TR No.	Sleeve	Cap
TR412AC	AS412	ST
TR413AC	AS413	ST
TR414AC	AS414	ST
TR418AC	AS418	ST

Optional Valve Caps



Colorful Sleeved Snap-in Valves

彩色真空胎气门嘴



TR413C-Y TR413C-P TR413C-R TR413C-B TR413C-G

TR No.	Sleeve	Cap
TR413C-Y	CS413-Y	GT-Y
TR413C-P	CS413-P	GT-P
TR413C-R	CS413-R	GT-R
TR413C-B	CS413-B	GT-B
TR413C-G	CS413-G	GT-G



TR414AC-Y TR414AC-P TR414AC-R TR414AC-B TR414AC-G

TR Number	Sleeve	Cap
TR414C-Y	CS413-Y	GT-Y
TR414C-P	CS413-P	GT-P
TR414C-R	CS413-R	GT-R
TR414C-B	CS413-B	GT-B
TR414C-G	CS413-G	GT-G



Snap-in Tubeless Valves

卡扣式气门嘴



TR600 SERIES HIGH PRESSURE SNAP-IN VALVES

TR600 系列高压卡扣式气门嘴

Ideal for light trucks For use to 100PSI/6.9 Bar cold inflation pressure maximum Recommended maximum rim thickness at rim hole is .205"/5.2mm.



TR No.	Rim Hole	A	B	C
TR600HP	.453"/11.3 mm	44	32	12
TR602HP	.453"/11.3 mm	63	51	12
TR801HP	.625"/15.7 mm	48	33	17
TR802HP	.625"/15.7 mm	66	51	17

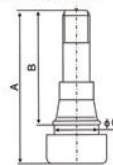

High Performance Tubeless Tire Valves

高性能无内胎气门嘴

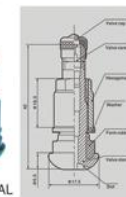

Rubber Grommet: RG
Washer: RW15
Nut: HN9
Cap: VEB

TR No.	Rim Hole	L	R
MS525S	.453"/11.3 mm	41.5	17.5
MS525L	.453"/11.3 mm	41.5	17.5
MS525AL	.453"/11.3 mm	42	17
MS525AL(black)	.453"/11.3 mm	42	17

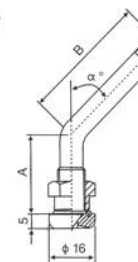

Single bend type

ETRTO NO.	A	B	α°
V3.20.2	30	60	27°
V3.20.4	25	60	27°
V3.20.5	25	40	27°
V3.20.6	25	85	27°
V3.20.7	25	50	27°
V3.20.8	29	85	12°
V3.20.9	45	52	12°
V3.20.10	50	25	27°
V3.20.12	25	70	27°

**Various Length and bend angles other than above specifications available upon request.

Optimal Shapes of Bottom

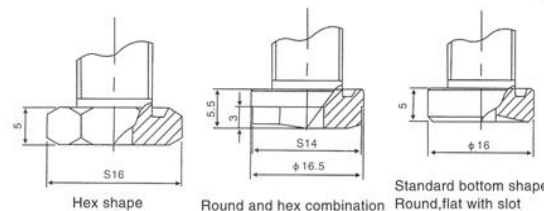

Optimal surface treatment for V3.20 series (Nickel Plated)



Rim Hole	Grommet	Nut	Core	Cap
.382 (9.7mm) / .394" (10mm)	V9.11.5 (RG60)	V9.13.1	9002#	DT (VC-L)



Clamp-IN Tubeless valves 压紧式真空胎气门嘴



TR570 SERIES STRAIGHT/BENT TYPE TUBLESS METAL CLAMP-IN VALVE FOR TRUCK AND BUS

TR570 系列直型/弯型卡车系列气门嘴

For drop center rims recommended torque at installation: 35-55 inch-pounds/4-6 Nm

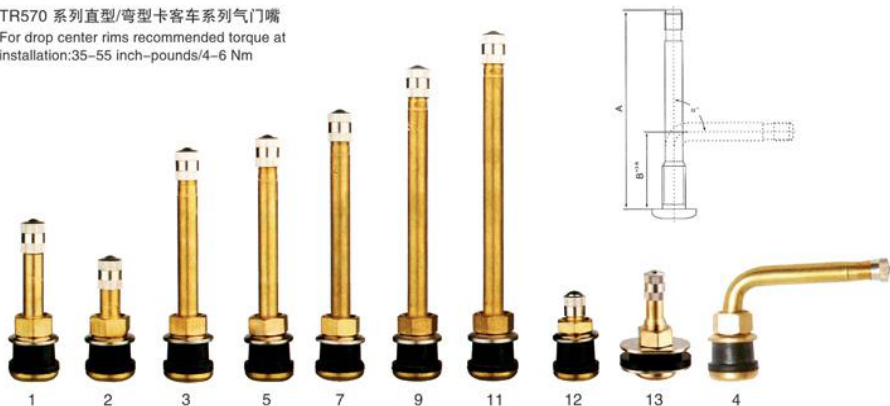

NO.	TR NO.	ETRTO NO.	Rim Hole	A	B	α
1	TR500	V3.21.3	.625" / 16mm	51	-	-
2	TR501	V3.21.2	.625" / 16mm	38	-	-
3	TR570	V3.21.4	.625" / 16mm	79.5	-	-
4	TR570C	V3.21.9	.625" / 16mm	79.5	33	90
5	TR571	V3.21.5	.625" / 16mm	86	-	-
6	TR571C	V3.21.10	.625" / 16mm	86	33	90
7	TR572	V3.21.6	.625" / 16mm	96	-	-

NO.	TR NO.	ETRTO NO.	Rim Hole	A	B	α
8	TR572C	V3.21.11	.625" / 16mm	96	33	90
9	TR573	V3.21.7	.625" / 16mm	111	-	-
10	TR573C	V3.21.12	.625" / 16mm	111	33	90
11	TR574	V3.21.8	.625" / 16mm	127	-	-
12	TR575	V3.21.1	.625" / 16mm	29	-	-
13	TR5010V		.625" x .875"	-	-	-

V3.20 SERIES METRIC RIM HOLE VALVE CLAMP-DOWN VALVES

V3.20 系列轮胎气门嘴

For wheel with wide base rims 15° tapered recommended torque at installation 12-15 Nm/ 105-130 inch-pounds



NO.	ETRTO NO.	RIM Hole	L
1	V3.20.1	390" / 9.7mm	36
2	V3.20.3	390" / 9.7mm	82

NO.	ETRTO NO.	RIM Hole	A	B	α
3	V3.20.2	.390" / 9.7mm	30	60	17
4	V3.20.4	.390" / 9.7mm	25	60	27
5	V3.20.5	.390" / 9.7mm	25	40	27
6	V3.20.6	.390" / 9.7mm	25	85	27
7	V3.20.7	.390" / 9.7mm	25	50	27
8	V3.20.8	.390" / 9.7mm	29	60	12
9	V3.20.9	.390" / 9.7mm	45	85	12
10	V3.20.10	.390" / 9.7mm	50	25	28
11	V3.20.12	.390" / 9.7mm	25	70	27



Clamp-IN Tubeless valves 压紧式真空胎气门嘴



TR540 SERIES TUBELESS O-RING SEAL CLAMP-IN VALVES FOR TRUCK

TR540 系列卡车O型圈密封气门嘴

For Alcoa aluminum truck wheels Recommended torque at installation 80-125 inch-pounds 9-14 Nm

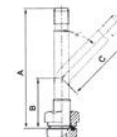

NO.	TR NO.	RIM Hole	A	B	C	α
1	TR542	.390" / 9.7mm	32	-	-	-
2	TR543	.390" / 9.7mm	58.5	-	-	-
3	TR543C	.390" / 9.7mm	58.5	23.6	35	45
4	TR543D	.390" / 9.7mm	58.5	25	35	60
5	TR543E	.390" / 9.7mm	58.5	25	35	75
6	TR544	.390" / 9.7mm	73	-	-	-
7	TR544C	.390" / 9.7mm	73	25	49	45
8	TR544D	.390" / 9.7mm	73	25	49	60
9	TR545	.390" / 9.7mm	89	-	-	-
10	TR545D	.390" / 9.7mm	89	25	66	60
11	TR545E	.390" / 9.7mm	89	25	66	75
12	TR546	.390" / 9.7mm	108.5	-	-	-
13	TR546D	.390" / 9.7mm	108.5	25	85	60
14	TR546E	.390" / 9.7mm	108.5	25	85	75
15	TR547	.390" / 9.7mm	119.5	-	-	-
16	TR547D	.390" / 9.7mm	119.5	25	96	60

TR510 SERIES TUBELESS Valves for Aluminium Disc Wheels

TR510 系列铝轮无内胎气门嘴

Used in drop-center aluminium disc wheels with 16 (.625") bottom valve hole Nickel plated



NO.	TR NO.	ETRTO NO.	Eff. Length	Ref. Length	Rim Hole
1	TR509	VS-946R	121/4-3/4	Φ23x139/90°	Φ16 (.625")
2	TR510	VS-879R	140/5-1/2	Φ23x139/90°	Φ16 (.625")
3	TR511	VS-949R	108/4-1/4	Φ23x139/90°	Φ16 (.625")
4	TV513 (TR513)	EX-513, SR7004A	Hor. L67/2-5/8	Φ23x139/90°	Φ16 (.625")
5	TV515 (TR515)	EX-515, SR7005A	Hor. L83/3-1/4	Φ23x139/90°	Φ16 (.625")

TR621A Series bent Type Valves

TR NO.	ETRTO NO.	Ret Length (mm. in.)	Ret Length (mm. in.)	Angle Bend
TR621A	V5.02.1	39 1.53	75 2.97	65°
TR622A	V5.02.2	44 1.75	11 4.53	90°
TR623A	V5.02.3	39 1.53	57 2.25	65°





Valve Accessories 气门嘴配件



Valve Cores 气门芯



Part No.	Description	Sealing Color & Finish	Working Pressure (Mpa)	Working Temp. Range (° C)	Suggested Installation Torque(N.m)
VC-A01	Short Valve Core,inside spring	black, nickle plated	0-1.5	-40- +150°C	0.17-0.34
VC-A02	Short Valve Core,inside spring	red, nickle plated	0-1.5	-40- +150°C	0.17-0.34
VC-A03	Short Valve Core,inside spring	black, brass finish	0-1.5	-40- +150°C	0.17-0.34
VC-A04	Short Valve Core,inside spring	red, brass finish	0-1.5	-40- +150°C	0.17-0.34
VC-B01	Long Valve Core,outside spring	black, nickle plated	0-1.5	-40- +150°C	0.17-0.34
VC-B02	Long Valve Core,outside spring	red, nickle plated	0-1.5	-40- +150°C	0.17-0.34
VC-B03	Long Valve Core,outside spring	black, brass finish	0-1.5	-40- +150°C	0.17-0.34
VC-B04	Long Valve Core,outside spring	red, brass finish	0-1.5	-40- +150°C	0.17-0.34
VC-C01	Short Valve Core,inside spring, for Large Bore	black, nickle plated	0-1.5	-40- +150°C	0.17-0.34
VC-C02	Short Valve Core,inside spring, for Large Bore	red, nickle plated	0-1.5	-40- +150°C	0.17-0.34
VC-C03	Short Valve Core,inside spring, for Large Bore	black, brass finish	0-1.5	-40- +150°C	0.17-0.34
VC-C04	Short Valve Core,inside spring, for Large Bore	red, brass finish	0-1.5	-40- +150°C	0.17-0.34
VC-D01	Long Valve Core,inside spring, for Large Bore	black, nickle plated	0-1.5	-40- +150°C	0.17-0.34
VC-D02	Long Valve Core,inside spring, for Large Bore	red, nickle plated	0-1.5	-40- +150°C	0.17-0.34
VC-D03	Long Valve Core,inside spring, for Large Bore	black, brass finish	0-1.5	-40- +150°C	0.17-0.34
VC-D04	Long Valve Core,inside spring, for Large Bore	red, brass finish	0-1.5	-40- +150°C	0.17-0.34



Tire Repair Parts 气门嘴修补工具



Valve caps 气门帽

Plastic Caps

**Various Colors upon your request



Plastic Dust Cap

Plastic Sealing Cap



Plastic Screwdriver Sealing Cap

Valve Core Tools 气门芯工具

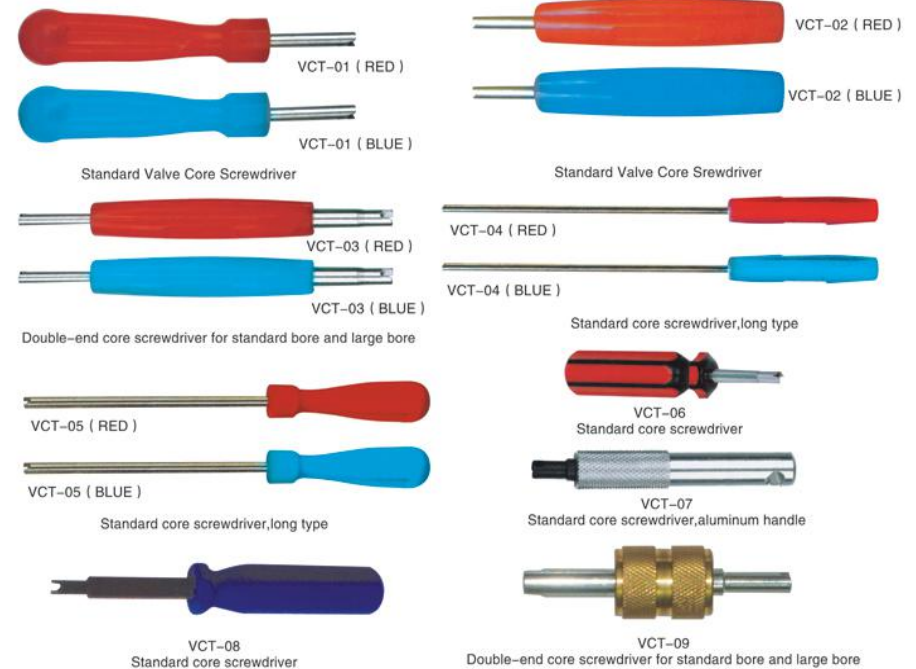



Tire Repair Parts 气门嘴修补工具



Four-way Valve Repair Tool 四通气门嘴维修工具



VCT-10
Core screwdriver, rethreads inside and outside part of stems, extracting damaged cores and deflating tires



VCT-11
Black hardened, Core screwdriver for standard bore and large bore, rethreading large bore valves, and deflating EM tires



VCT-12
Core screwdriver, the same function as BVT-21



VCT-13
Standard bore and large bore and deflating tires, chromed plated



VCT-14
Black hardened, with the same function as BVT-21



VCT-15
Black hardened, with the same function as BVT-21. For large bore application

Two-way Valve Repair Tool



VCT-16
Core Screwdriver and deflator



VCT-17
Standard chain valve fishing tools
Aligns and holds valve in position with valve hole while mounting tires



VCT-18
Cable valve finishing tool
Same function as BVT-35



VCT-19
Cable valve finishing tool
Aligns and holds valve in position with valve hole while mounting tire.
Contains valve core screwdriver and deflator

Valve Mounting Tools 气门嘴拉出器



VMT-01
Snap-in valve mounting tool



VMT-06
Valve cap tool



VMT-02
Snap-in valve mounting tool, easily pulls the snap-ins to be seated.



VMT-07 Green



VMT-03
Valve cap tool



VMT-04
Snap-in valve mounting tool, easily pulls the snap-ins to be seated.



VMT-07 Blue

Poly snap-in valve mounting tool, installs tire valves without cratching rims.



VMT-08

For fast installation of metal clamp-in valves. Fits straight tubeless truck and passenger clamp-in valves.



VMT-09

Quick snap-in valve mounting & demounting tool.



Wheel Weight Tools 平衡块工具



PHG-001A



PHG-001C



PHG-001B



PHG-034



PHG-001AC



PHG-002



PHG-003



PHG-003AC



PHG-031B



PHG-031A



PHG-031C



PHG-031D



PHG-015



PHG-014

CLIP-ON WHEEL WEIGHT PLIERS 挂钩平衡块工具

Part NO.	Description
PHG-001A	Forge Wheel Weight Pliers Nickel Plating
PHG-001B	Forge Wheel Weight Pliers Black
PHG-001C	Forge Wheel Weight Pliers
PHG-002	Forge Wheel Weight Pliers Nickel Plating
PHG-003	Wheel Weight Pliers
PHG-034	Heavy-Duty Wheel Weight Pliers
PHG-001AC	Plastic Cap For Forge Weight Pliers
PHG-003AC	Cap Accessories for PHG-003

ADHESIVE WHEEL WEIGHT TOOL 粘帖平衡块工具

A high-impact plastic chisel designed to remove adhesive wheel weights quickly without damaging expensive rims. Simply pry the weight off with a light tap of a hammer. The edge can be re-sharpened for extended use.

Part NO.	Description
PHG-031A	Adhesive wheel weight removal tool Big Handle
PHG-031B	Adhesive wheel weight removal tool Small Handle
PHG-031C	Adhesive wheel weight removal tool Short
PHG-031D	Adhesive wheel weight removal tool Short

Body option colour



WHEEL WEIGHT HAMMER 平衡锤

Part NO.	Description
PHG-014	Non-Lead Clip-on Truck Wheel weight Hammer
PHG-015	Non-Lead Clip-on Truck Wheel weight Hammer



Tire Repair Patch Tools 补片修补类工具



THG-009

THG-008

THG-021

THG-018

THG-020



PHG-010



PHG-011



THG-016A



THG-016C



THG-016B



THG-016D



PHG-074

PHG-045



PHG-075



PHG-006



TRC-002W



TRC-002Y

STITCHERS 滚轮工具

Part NO	Roller dia. (mm)	Thickness (mm)
THG-008	38	2/2.5/3/4/5/6
THG-009	50	4/5/6
THG-018	38	42
THG-021A	38	2/2.5/3/4/5/6
THG-021B	50	4/5/6
THG-020	2 in 1 Metal Tire Stitcher 150mm*30mm	

SCRAPERS 刮刀工具

Part NO	Description
PHG-010	Hoe Style Inner Liner Scraper
PHG-011	Blade Style Inner Liner Scraper

SKIXING KNIVES 橡胶刀

Part NO	Description
THG-016A	X2T taper skiving knife
THG-016B	X1Y extra curve sharp skiving knife
THG-016C	X3N round point flexible blade skiving knife
THG-016D	Utility Knife

APPLICATORS 刷子系列

Part NO	Describe	Head Dia (mm)	Hair Length (mm)	Pole Dia (mm)	Pole Length (mm)
PHG-074A-2	2#	19.5	38	9	160
PHG-074A-4	4#	24	38	10	160
PHG-074A-6	6#	29.5	38	10.5	160
PHG-074A-8	8#	35	38	13	162
PHG-074A-10	10#	38	44	16.5	170
PHG-074A-12	12#	43	44	17	170
PHG-074A-14	14#	48	44	18	180
PHG-074A-16	16#	54.5	44	19.5	180
PHG-074A-20	20#	65	51	21.5	185
PHG-074A-22	22#	69.5	51	21.5	185
PHG-045	Large	46	45	28	390
PHG-075	Cotton Tire Swab				

CRAYONS AND HOLDER 记号笔和套筒

Part NO	Description
PHG-006	Tire Crayon Holder
TRC-002W	White Color Tire Crayons
TRC-002Y	Yellow Color Tire Crayons



Tire Repair Material 轮胎修补材料



Tire Seal String 补胎胶条



TS-01

TS-03

TS-05

TS-07



TS-02



TS-04

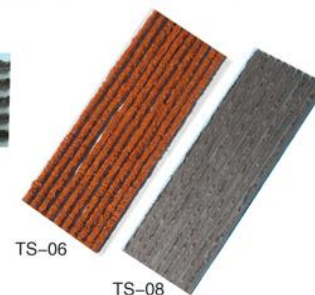

TS-06

TS-08

PVC covering both side or PVC+paper covering each side

Part NO	Color	Length		
		mm	mm	Inch
TS-01	Brown	6	100	4
TS-02	Brown	6	200	8
TS-03	Brown	3.5	100	4
TS-04	Brown	3.5	200	8
TS-05	Black	6	100	4
TS-06	Black	6	200	8
TS-07	Black	3.5	100	4
TS-08	Black	3.5	200	8

Tire Mounting Paste 轮胎润滑膏



● Extra-slippery lubricant for mounting tires with stiff beads and to aid in bead seating.No water or mixing required.Use directly from the container

● Brushes on in seconds to protect rim investment and speed mounting and dismounting.

● Used in the temperature higher than -4°C



For Trucks



For Cars



Brush



Tyre Repair Tools
轮胎修补工具



Tyre Repair Tools
轮胎修补工具



Insertion & Probes



HRT01

Part No.	Desc.
HRT-01A	Split eye plugger
HRT-01B	T-handle split eye plugger
HRT-01C	Pistol grip split eye plugger
HRT-01D	Pistol grip split eye plugger

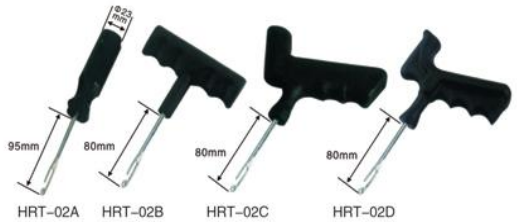

HRT02

Part No.	Desc.
HRT-02A	Side open eye plugger
HRT-02B	T-handle split eye plugger
HRT-02C	Pistol side openeye plugger
HRT-02D	Pistol side open eye plugger



HRT03

Part No.	Desc.
HRT-03A	Closed eye plugger
HRT-03B	T-handle closed eye plugger
HRT-03C	Pistol closed eye plugger
HRT-03D	Pistol closed eye plugger



HRT04

Part No.	Desc.
HRT-04A	Screwdriver smooth reamer
HRT-04B	T-handle smooth reamer
HRT-04C	Pistol grip smooth reamer
HRT-04D	Pistol grip smooth reamer



BRT105

Part No.	Desc.
HRT-05A	Reamer
HRT-05B	T-handle reamer
HRT-05C	Pistol grip reamer
HRT-05D	Pistol grip reamer



BRT106

Part No.	Desc.
HRT-06A	Reamer
HRT-06B	T-handle reamer
HRT-06C	Pistol grip reamer
HRT-06D	Pistol grip reamer



BRT107

Part No.	Desc.
HRT-07A	Screwdriver rough reamer
HRT-07B	T-handle rough reamer
HRT-07C	Pistol grip rough reamer
HRT-07D	Pistol grip rough reamer

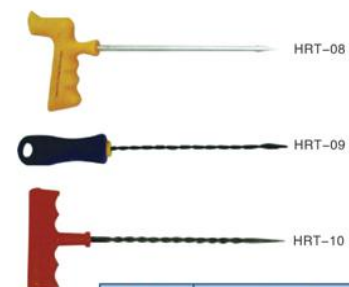

Part No.	Desc.
HRT-08	Screwdriverreamer 350mm
HRT-09	Longer Probe Tool
HRT-10	T-handle screwprobe 245mm

4 In T-handle Combination Tool





Tyre Repair Kits 轮胎修补工具套装



河北特莱斯汽车配件有限公司
HEBEI HOLMAN Auto Parts Co.,Ltd.



RK-01
1PC-T-handle(metal)plugger
1PC-T-handle(metal) reamer
1PC-12ml cement
1PC-Needle changerable tool
5PC-4" string



RK-02
1PC-T-handle front eye open plugger
1PC-T-handle screwdrive reamer
1PC-12ml cement
5PC-4" string



RK-03
1PC-pistol handle front eye open plugger
1PC-pistol handle screwdrive reamer
1PC-12ml cement
5PC-4" string



RK-04
1PC-stright handle side eye open plugger
1PC-stright handle reamer
1PC-12ml cement
5PC-4" string



RK-05
1PC-Pistol handle front eye open plugger
1PC-Pistol handle reamer
1PC-12ml cement
5PC-8" string



RK-06
1PC-Pistol Handle tool
4PC-Tire repair needles
1PC-12ml cement
5PC-8"String
1 PC-Replacement tool



RK-07
1PC-4 IN 1 T-Handle combination tool
5PC-4" string



RK-08
1PC-T-handle side eye open plugger
1PC-12ml cement
PC-4" string



RK-09
1PC-pistol handle side eye open plugger
1PC-pistol handle reamer
5PC-4" string



RK-10
1PC-pistol handle front eye open plugger
1PC-pistol handle screwdriver
5PC-4"string dia.5mm
1PC-Needle changerable tool



RK-11
1PC-pistol handle front eye open plugger
1PC-pistol handle screwdriver probe
1PC-12ml cement
5PC-8"string dia.5mm

*Blister Card can be made as your request.



WHEEL BALANCE WEIGHTS



河北特莱斯汽车配件有限公司
HEBEI HOLMAN Auto Parts Co.,Ltd.



地址:中国河北省沧州市献县垒头乡横上村
Add.:Hengshang Village,Leitou town,Xian County,
Cangzhou city,Hebei province,China

Tel:0086-317-4694999 5299455
4452799 4452899

Fax:0086-317-4692999

E-mail:lt1297@163.com sales@holmanwheelweight.com

Http://www.ltqp.com www.chinawheelweights.com

Https://holman.en.alibaba.com

2018 Version
版权所有，翻版必究！

河北特莱斯汽车配件有限公司
HEBEI HOLMAN Auto Parts Co.,Ltd.